

Contents

	Page
1. Technical data of GENEVA PALEXPO	1
1.1 Connection of utilities to stands	1
1.2 Floor loads	1
1.3 Access-ramp loads	1
2. Stand building	2
2.1 Attachments	
a) Floors	2
b) Walls	2
2.2 Suspensions	2
2.3 Air-conditioning of stands	3
2.4 Through-stand aisles leading to an emergency exit	3
2.5 Structures overhanging gangways	3
2.6 Exits	3
2.7 Glazing	3
2.8 Turntables	3
2.9 Balloons	3
2.10 Laser shows	4
3. Multistorey structures	4
3.1 Approval of plans	4
3.2 Floor loading calculation of structural elements	4
3.3 Permissible local stress on the floor	5
3.4 Lifts - Temporary installations for the transport of people	5
3.5 Stairways / Gangways / Platforms	5

1. Technical data of GENEVA PALEXPO

1.1 Connection of utilities to stands

Connection points are located in connection boxes at floor level. These boxes are indicated on the hall plans by the following symbols:

- ☒ = Electricity + Telecommunication + Radio + Television
- ☐E = Water and drainage
- ☐A = Compressed air
- ☐G = Gas
- E = Water

NB: Halls 6 and 7 have a network of gutter channels connecting the floor boxes.

Gutters are shown on the plan.

Exhibitors are strictly forbidden to make their own connections to the floor boxes.

Floor boxes in use must be accessible at all times.

It is forbidden to touch the electric installation of the goods entrances.

All on-stand installations will be inspected by official controllers, fully empowered to authorize or prohibit the installations, or to require alterations to be made to meet technical and legal requirements.

Exhibitors are responsible for the cost of modifying equipment that does not comply with the regulations.

Exhibitors are liable for any technical faults or damage that may result from non-compliance with the provisions laid down by GENEVA PALEXPO.

Exhibitors may not object to cables and pipes being laid over their stand site to supply neighbouring stands, if necessary.

Modular raised flooring consisting of standard wood frames can be rented from GENEVA PALEXPO which would facilitate the passage of cables (see relevant order form).

In areas open to the public, a raised floor is essential for covering high-voltage electricity cables, and water supply and discharge pipes.

Exhibitors must specify that their stand contractor use NON-SLIP materials to ensure that floors, floorings and other surfaces, incl. gangways, stairs, etc., have non-slip surfaces.

1.2 Floor loads (admitted: 1 kg = 10 N)

Load limits apply as follows:

Entrance Hall, Conference Centre and Lobby ("Foyer")

A uniformly distributed average load of $p = 4000 \text{ N/m}^2 = 4 \text{ kN/m}^2$.

Halls 1 and 2

The average load is 5 kN/m^2 . Uniformly distributed over an area of $9.60 \text{ m} \times 9.60 \text{ m}$, this may be replaced by one of the following alternatives:

- a) two concentrated 180 kN loads plus one uniformly distributed load of 1 kN/m^2
- b) two axles of 180 kN plus one uniformly distributed load of 1 kN/m^2
- c) one 240 kN load, including live load plus one uniformly distributed load of 2.5 kN/m^2
- d) two axles of 120 kN plus one uniformly distributed load of 2.5 kN/m^2 .

Halls 3 and 4

One uniformly distributed average load, similar to that allowed for road surfaces. For all loads exceeding 10 kN/m^2 the exhibitor must obtain permission from GENEVA PALEXPO's Technical Department, which will, if necessary, seek the expert advice of civil engineers Tremblet S.A.

Hall 5

One uniformly distributed average load of 10 kN/m^2 , which may be replaced by one of the following alternatives, over areas of $9.60 \text{ m} \times 7.20 \text{ m}$, or $7.20 \text{ m} \times 7.20 \text{ m}$:

- a) 2 concentrated loads of 180 kN plus one uniformly distributed load of 4 kN/m^2
- b) two axles of 180 kN plus one uniformly distributed load of 4 kN/m^2
- c) 1 load of 240 kN, including live load plus one uniformly distributed load of 6 kN/m^2
- d) 2 axles of 120 kN plus one uniformly distributed load of 6 kN/m^2 .

Hall 6

One uniformly distributed load of maximum 20 kN/m^2 which may be replaced by max 500 kN concentrated loads spaced by 7 m in both directions acting simultaneously with 5 kN/m^2 of distributed load on floor.

Hall 7

One uniformly distributed average load of 10 kN/m^2 , which may be replaced by one concentrated load of 240 kN including live load, plus one load of 6 kN/m^2 , uniformly distributed over an area of $7.20 \text{ m} \times 7.20 \text{ m}$ around the concentrated load.

Bars 5 and 6

Max. permitted roof load: 5 kN/m^2 .

1.3 Access-ramp loads

The access ramp to Halls 1 and 2, on the Lyon side, can carry two 180 kN axle per 9.60 m span.

The access ramp to Halls 4 and 5, on the Lyon side, can carry two 180 kN axles per 9.60 m or 7.20 m span.

The access ramps to Hall 5 and 6, on the Lausanne side, can accept the normal loads for roads and bridges, subject to normal load tolerances (art. 9, SIA 160 standards, 1970 edition).

Special equipment

Permission must be obtained from GENEVA PALEXPO Technical Department for any special equipment, such as crane trucks, lifting gear etc., whose weight exceeds one of the load limits specified above. If necessary, the expert opinion of the relevant civil engineering office will be sought, viz.:

- for Halls 1 to 6:

Tremblet SA

18, Quai du Seujet
CH-1201 Geneva

Tel.: +41 (0)22 716 08 00

Fax: +41 (0)22 716 08 99

email@tremblet.ch

- for Hall 7 :

Guscetti & Tournier SA

Rue du Pont Neuf 12
CH-1227 Carouge/Geneva

Tel.: +41 (0)22 308 88 88

Fax: +41 (0)22 308.88.99

contact@gti.ch

www.gti.ch

2. Stand building

Stands must conform to basic safety standards and must not present a danger to occupants or visitors, or to the immediate environment.

Exhibitors are responsible for the construction and decoration of their stands. They should refer first to the rules of the exhibition, which prevail.

Each exhibitor must ensure that he knows the location, dimensions and layout of the stand allocated to him. The Secretariat of GENEVA PALEXPO is available to arrange visits.

Please also refer to Heading "Safety and Security / Fire prevention".

2.1 Attachments

a) Floors

We advise exhibitors and stand designers to create self-supporting structures that do not have to be attached to the floor.

All halls

Holes may not be made in the floors.

Entrance Hall, Conference Centre and Lobby ("Foyer")

Scotch tape or adhesive stickers are forbidden on the floor.

Plants put on the marble floors should be in waterproof pots. The costly removal of water stains will be invoiced to the exhibitor.

b) Walls

Entrance Hall, Conference Centre and Lobby ("Foyer"), Hall 3

It is forbidden to fix anything to the walls.

Halls 1, 2, 4 and 5

Nails and screws may be driven into the 3.00 m high plywood panels fixed to the wall round Halls 1, 2, 4 and 5, but drilling holes right through the panels, applying paint, or sticking tapestry or wallpaper to them are prohibited.

Before vacating the site, the exhibitor must remove all remaining items such as nails, screws, staples, adhesive tape, etc.

Welding and fixing any item to the metal framework of the building is prohibited.

Hall 6 and 7

It is forbidden to fix anything to the interior cladding of the facade or to the supporting metal girders.

2.2 Suspensions

Entrance hall

Because of the existing signposting and advertising boards, no other suspension is permitted.

Conference Centre - Rooms A, B, C - and "Foyer"

A certain number of attachment points are fixed in the false ceiling. No suspension will be permitted outside these hooks. Moreover the maximum load admitted will depend on the occupancy of Hall 1.

Halls 1, 2, 3, 4, 5, 6 and 7

Attachment of devices to the steelwork of Halls 1 - 6, to the ceiling structures of hall 3 or to the appropriated hooks in the wooden framework of Hall 7, may be authorized provided they are carried out by GENEVA PALEXPO's staff exclusively. Previously the exhibitor should submit to the Technical Services Department a plan with following indications for every attachment point:

- measurements from stand edges
- height from the hall floor
- weight per attachment.

In borderline cases, approval by a civil engineering office will be required.

All halls

Suspensions must conform with the Swiss static suspension safety standards.

GENEVA PALEXPO accepts no liability if, for reasons beyond its control, work is not completed within the deadline mentioned in the order form.

Suspension work is carried out entirely at the exhibitor's risks.

GENEVA PALEXPO is liable only for the cable installed by its own staff and not for damage caused by the fall of any item suspended in a manner that does not conform to safety regulations.

All work will be charged according to time involved even though an estimate has been established.

Veils / False ceiling

Suspensions require a special authorization from the technical department to ensure that outlets of air ventilation ducts are not obstructed.

2.3 Air-conditioning of stands

Only water-cooled systems are allowed. All air exchange systems are prohibited for reasons of heat build-up.

A fine of CHF 2'000.- per unit will be collected in case of non-observance and the installation put out of working.

2.4 Through-stand aisles leading to an emergency exit

See also Heading "Safety and security / Fire prevention", para 1.4 Safety zone.

- a) When a public aisle crossing a stand leads straight to an emergency exit, the exhibitor may cover the floor with plain carpet (no identification, no publicity) of his choice. The carpet must
- be of contrasting colour,
 - or be marked at the edges by rows of studs at least 10 cm in diameter, set 70 cm max. apart.

Whatever method is chosen for identifying the emergency aisle, it must be easily recognised as such. The Security Service has the final ruling on this matter.

- b) Other aisle coverings

All other aisle coverings must be clearly shown on the stand-layout drawings: these require prior authorization by Technical Department, which is responsible for maintaining optimal conditions for free movement of vehicles in the halls, in the interest of all users.

Minimum requirements are as follows:

- Quality of materials and their installation:
The overall structure of the gangway covering, including a 6 % access ramp, must be capable of carrying loads of 8 tonnes per wheel to allow fully loaded vehicles of any type to use the aisles.

Height of flooring

As a rule, maximum 5 cm, carpet included.

However, height of flooring may reach 15 cm max, if this matches the floorings bordering the gangway.

Exhibitors are urged to seek agreement with adjacent standholders, where necessary, for adjusting the heights of their floorings, or for installing a connecting ramp.

The flooring must have a clean finish and a 6 % ramp at both ends.

This flooring should not bear any identification or advertising.

2.5 Structures overhanging gangways

The lowest point of structures overhanging gangways must be at a minimum height of:

- 4.20 m from hall floor, if the structures overhang gangways leading to goods entrances.
- 2.50 m from hall floor, for other gangways.

2.6 Exits

Stands with multi-level structures or enclosed space where several people can be accommodated, must be provided with exits, as follows:

- a) up to 50 people: one exit, 0.90 m wide
- b) up to 100 people: two exits, each 0.90 m wide
- c) up to 200 people:
either three exits, each 0.90 m wide or two exits, the first 0.90 m wide, the second 1.20 m wide
- d) more than 200 people:
two or more exits at least 1.20 m wide, where the total exit widths must be at least:
- on the ground floor: 0.60 m wide per 100 people or part thereof,
 - on the upper floors: 0.60 m wide per 60 people or part thereof.

The number of people per level, to be computed on the basis of one per square metre, is defined by the surface area of this level (the area enclosed by its perimeter), less 15 % allowance for installations.

In addition, the lighting and marking of emergency exits must conform to current safety regulations.

See also para 3.5 Stairways / Gangways / Platforms.

2.7 Glazing

All glazing must be of laminated safety glass, film-covered plate glass, or equivalent.

2.8 Turntables

Exhibition turntables must be so designed as to prevent accidents. The area surrounding them must be guarded to prevent fingers or flap-ends of garments being caught in the machinery.

2.9 Balloons

Balloons may be admitted under the following conditions:

- helium-filled balloons (any other gas is definitely excluded) are permitted only for decoration purposes;
- for all other uses (distribution, etc.) only balloons filled with compressed air are allowed.

In all cases, written authorization must be obtained from the Organizer and the GENEVA PALEXPO Security Service.

If balloons have to be fetched from the ceiling, the cost of the manlift will be invoiced at the hourly rate.

2.10 Laser shows

Laser installations and related optical and electrical installations have to be set up in such a way as to be out of reach of the public.

Lasers, optical lasers and all the elements that divide and modulate the beam must be fixed on an optical bench or a stable assembly board to prevent any of the various elements of the installation from being accidentally knocked over or displaced. Shifting or adjusting these elements cannot be done in the presence of the public. For all assembly or adjustment work on lasers in use, operators have to wear protection glasses, or, as the case may be, adjusting glasses.

No direct laser beam nor any part thereof after its division may ever reach the public area, even after numerous reflections on reflecting surfaces; to that effect, the beam and its reflections must always be projected at a minimum of 2.5 m above the floor. If a projection is planned into the audience during the laser show, proof has to be given that the maximum allowed exposure will not be exceeded in any section accessible to the public.

For class 4 lasers, the beam has to be widened to prevent the energy of the direct or of the reflected beam from generating a temperature exceeding 80°C at point of impact in any part of the room, even in continuous use.

Only fire-resistant materials or wall coverings are allowed in the laser risk zone. A metallic screen has to be placed at the beam outlet to prevent laser radiations from reaching the public, in case of accidental deviation of the optic.

Demonstrations with laser installations

In view of the high risks associated with class 4 laser installations, these should, as much as possible, not be used for public demonstrations.

Should this equipment however be used for specific demonstrations, the following need to be observed:

- the operator is responsible for the safety of the spectators
- the practical demonstration has to be adjusted in the absence of the public
- the laser installation has to be secured against any accidental displacing of the optical elements
- the spectators should be kept off the installation by partitions before and during the demonstration
- the path of the beam should not be readjusted or corrected in the presence of spectators.

3. Multistorey structures

Complementary information to § 2 " Stand Building "

3.1 Approval of plans

At least two months before the opening of the show, a file in duplicate containing the following documents must be submitted to GENEVA PALEXPO's Technical Department, for approval, viz.:

- Architects' and decorators' plans showing alignments and dimensions.
- Engineering drawings, accompanied by notes of static calculations carried out by a civil engineer guaranteeing adherence to static loading standards.
- The principal hypotheses and the summary of the results must be presented in a separate file containing:
 - a) a summary of the calculation hypotheses in condensed form;
 - b) a schematic diagram for all calculations carried out;
 - c) a summary of the results in the form of graphics and tables showing all the loads and strains;
 - d) plans showing the positions, in relation to the periphery of the stand, of point loads acting at the bases of pillars.
- Exhibitors must construct the load-bearing structures in accordance with plans approved by the GENEVA PALEXPO's Technical Department. The appropriate civil-engineering office is responsible for checking the assembly of these structures.

3.2 Floor loading calculation of structural elements

- a) Levels of floor loading, which depend on the use of the premises, must not exceed the following maxima:
 - offices: $p = 200 \text{ kg/m}^2$
 - exhibition space: $p = 300 \text{ kg/m}^2$
 - conference rooms: $p = 300 \text{ kg/m}^2$
 - bars: $p = 300 \text{ kg/m}^2$

P1: average excess loading on the exhibition floor

P2: average permanent loading (load-bearing structures, fittings, furniture etc.), plus average extra mobile loads

P3: average permanent loading (load-bearing structures, ceilings etc.).

The condition to be satisfied is:

$P = P1 + P2 + P3$, where P is the average uniformly distributed loading (stress) according to article 1.2 Floor loads.

The elements of load-bearing structures must be designed for the carrying capacities indicated above.

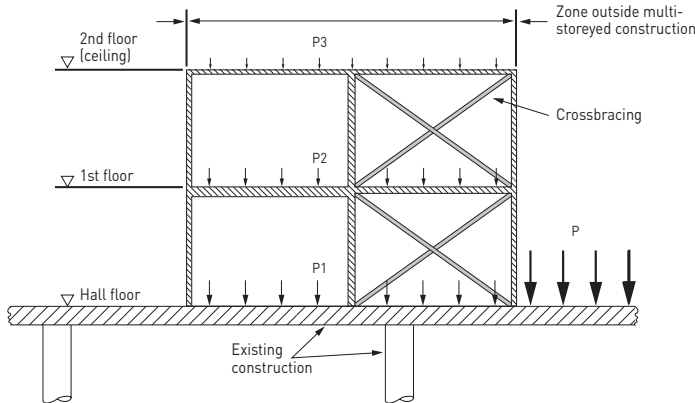

- b) Horizontal stability must be assured by an appropriate cross-bracing system.
- c) Any vertical element inside or on the periphery of a stand must withstand either a horizontal load of 20 kg/m², or a point load of 200 kg applied at its highest point.

3.3 Permissible local stress on the floor

The areas of floor support plates must be calculated for a permitted max. local stress of:

$$q \text{ loc. max.} = 6 \text{ kg/cm}^2.$$

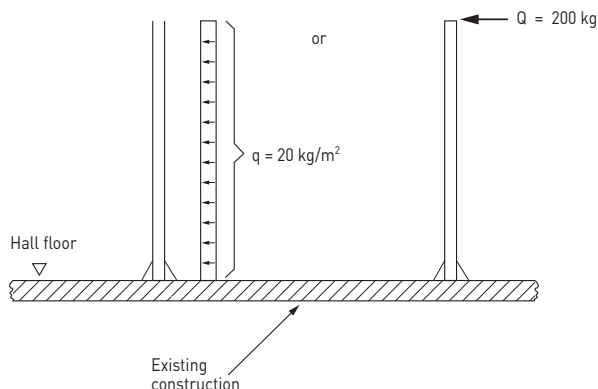

3.4 Lifts - Temporary installations for the transport of people

For all mobile equipment such as lifts or service lifts (whether or not for the transport of people) and escalators:

- a) applications must be made to the Department of Public Works:

Département du territoire (DT)

Service de la Sécurité-Salubrité

Rue David-Dufour 1

CH-1205 Geneva

Tel.: +41 (0)22 327 43 54

- b) installation may only be carried out by a contractor approved by the Department of Public Works.

The SIA standards applicable are as follows:

Cable elevators:	SIA 370/10
Hydraulic elevators:	SIA 370/11
Escalators:	SIA 370/12

These standards may be obtained from the following address:

Schweizerischer Ingenieur- und Architekten-Verein SIA

Generalsekretariat

Tödistrasse 47

CH-8002 Zürich

P.O. Box

CH-8039 Zürich

Tel.: +41 (0)44 283 15 15

Fax: +41 (0)44 283 15 16

contact@sia.ch

www.sia.ch

3.5 Stairways / Gangways / Platforms

See also para 2.6 Exits.

Stairways must have a minimum usable width of 1.00 m and be provided with 1.00 m high handrails measured at the most dangerous point. As a general rule, stairs shall consist of straight or nearly straight flights, and the slope shall not exceed 35°.

Openings leading to a drop must be closed off by safety rails 1.00 m high and bars close enough together to prevent a sphere 15 cm in diameter from passing between them. In addition, the bars should be so designed as to discourage people, children in particular, from climbing up them.

Gangways, platforms and ladders as of 50 cm from the ground must be provided with handrails and retaining barriers 1.00 m high.

Spiral staircases

Spiral staircases cannot be used as the only means of escape from stands with an upper story.

The steps must have a minimum width of 1.50 m.

The French version of these Regulations is the authentic text.